

NHM Series Hydraulic Motor

Product Feature:

NHM series of low-speed and high-torque hydraulic motors with crankshaft and connecting rod are produced according to the technology and standard provided by Italy. On such a foundation, we also have constant technological improvement according to market demand, so as to improve the performance of the products.

The main features include:

1. Low noise due to an eccentric crankshaft and low excitation frequency of five-piston design;
2. Revolve steadily under very low speed due to high starting torque and good low-speed stability;
3. Good reliability and less leakage due to the patented flat compensation distributor, special sealing between piston and plunger bushing guarantees higher volumetrical efficiency;
4. High mechanical efficiency due to roller bearing between crankshaft and connecting rod;
5. Reversible rotation, and the output shaft can bear certain external force from both radial and axial directions;
6. High power-mass ratio, small volume and light weight.

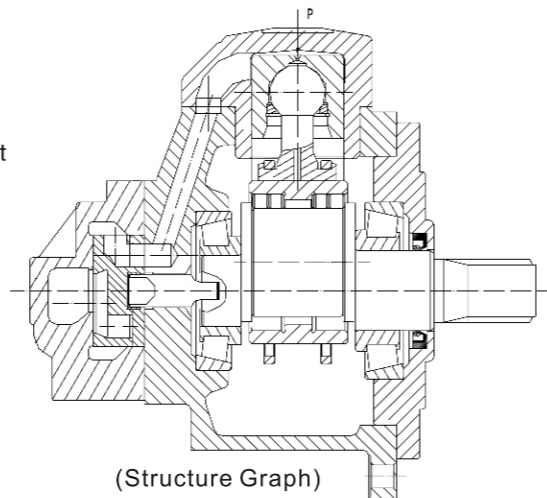

Calculation:

1. Actual output torque : $M=0.159 (P_1-P_2) V \cdot \eta_m$ (N.m)

where : P_1, P_2 ----- (MPa) inlet and outlet pressure (MPa)
 V ----- displacement (ml/r)
 η_m -----mechanical efficiency (%)

2. Output power : $N=\frac{M \cdot n}{9550}$ (kW) $N=\frac{q (P_1-P_2)}{60000} \eta_m \eta_v$ (kW)

where : n ----- speed (r/min)
 q ----- input flow (ml/min)
 η_v ----- volumetrical efficiency (%)

3. Speed : $n=\frac{q}{V} \eta_v$ (r/min)

Note:

1. Filtration: the recommended filtration precision for normal industrial use is 25 μm, and allowable precision low pressure, low speed or interval is 75 μm.
2. Oil viscosity: the optimum performance could only be obtained under proper oil viscosity between 15–100cst.
3. Before the first start-up, it must fill hydraulic oil in the hydraulic motor body, to avoid the damage.
4. Leakage: drain port should be connected separately to the tank. Normally the maximum pressure for the motor body is 0.1 Mpa, and it could also be improved to bear 3–5 Mpa, to meet special requirements.
5. The top line of the drain pipe should be higher than that of the motor body, in case emptying oil storage.
6. Installation: motor can be installed in any position with rigid support, When installed, shafts of the motor and its transmission should be concentric.
7. Cleanness: Strictly maintain the cleanness of the oil port, and keep any solid particles away.
8. Release both the radial and axial loads of the output shaft to enable longer life of the motor.
9. NHM motor could not work as a pump.

Order Code

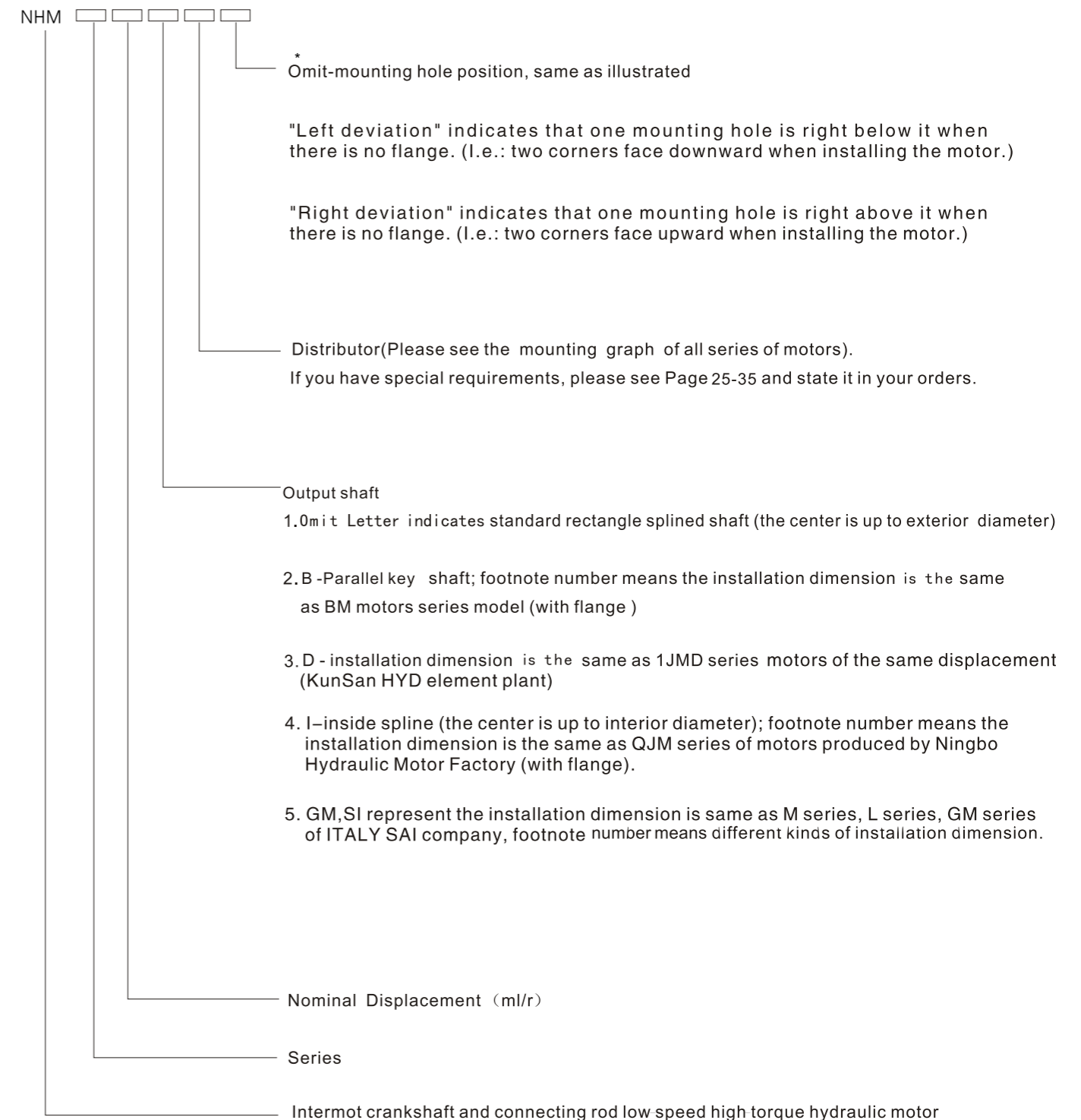

"Left deviation" and "Right deviation" are only applicable for NHM2–NHM11 series of motors, and oil inlet and outlet are horizontal. (Same as illustrated)

NHM11-700~1300 Mounting Data

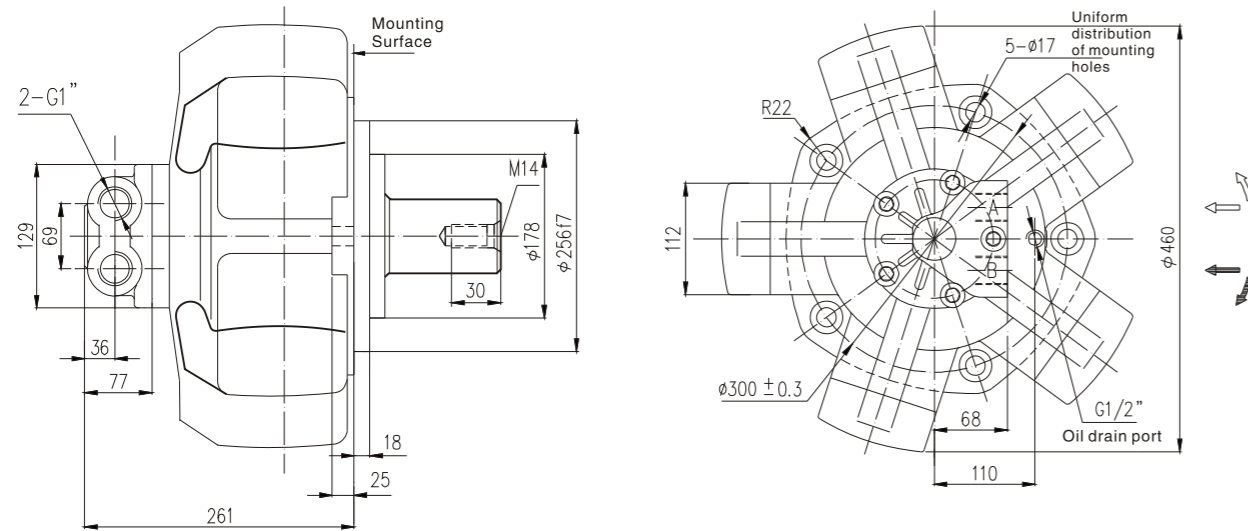

Standard outside spline
NHM11-**

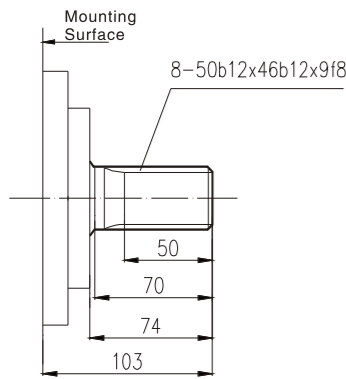

Standard parallel key
NHM11-**B

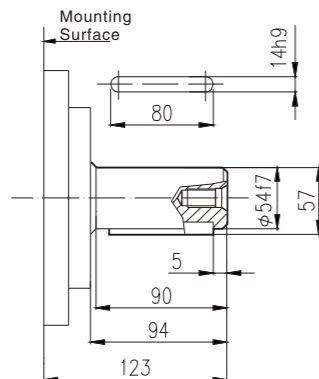

Standard inside spline
NHM11-**I

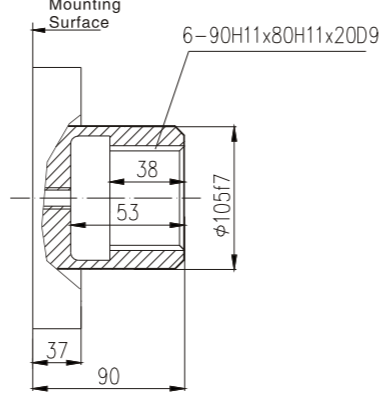

NHM11-**SL₃

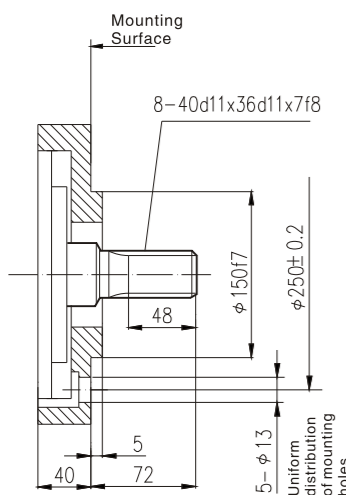

NHM11-**SL₄

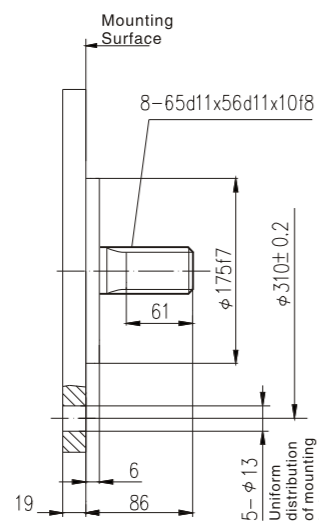

NHM11-**SL₅

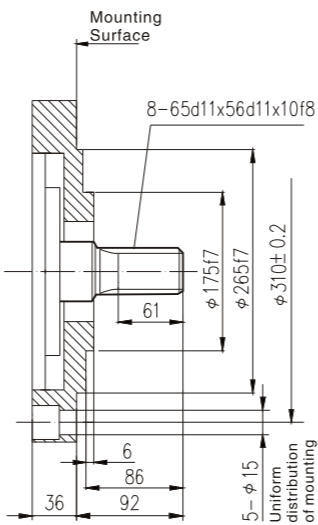

NHM11-700~1300 Mounting Data

NHM11-**SM₄

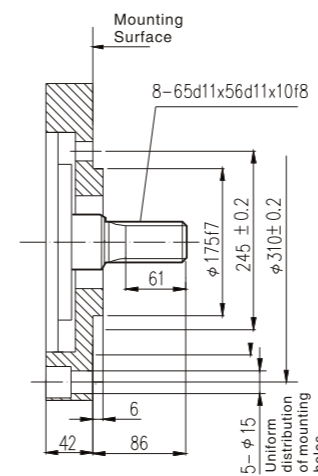

NHM11-**N

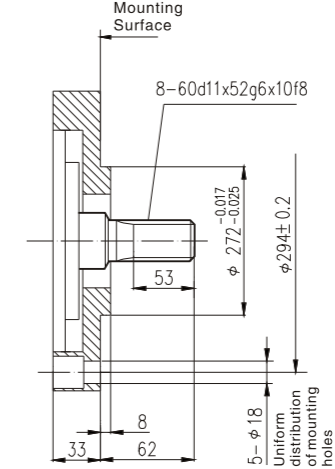

NHM11-**N₁

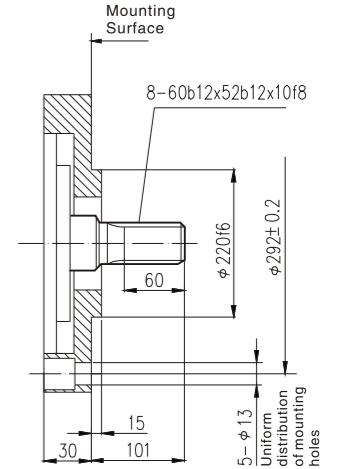

NHM11-**K

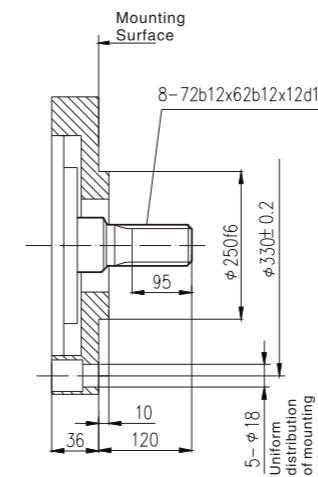

NHM11-**B₄

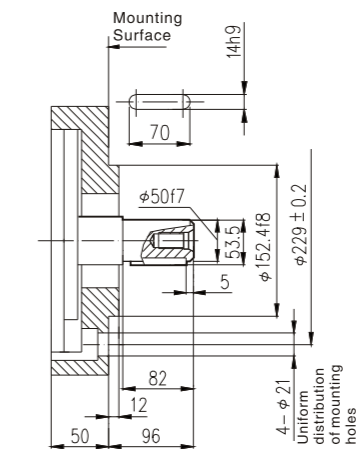

NHM11-**B₆

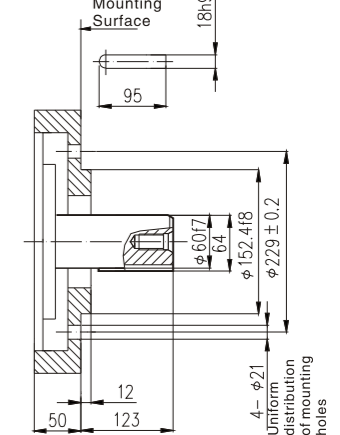

NHM11-**B₃₅

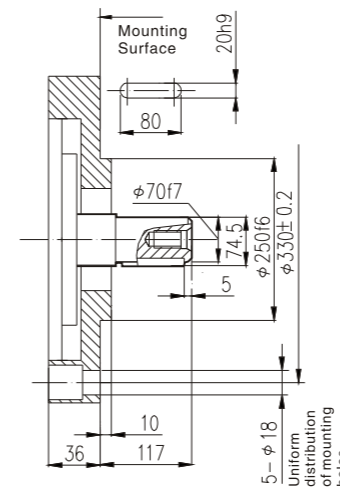

NHM11-**B₄₆

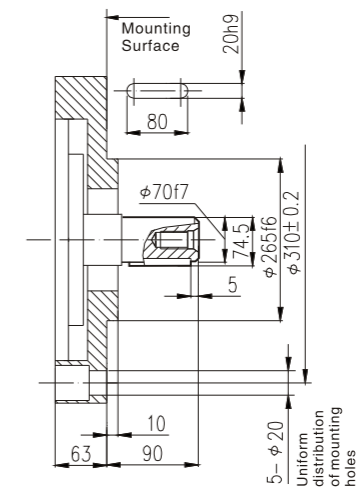

NHM11-**I₂₁

